

---

# LSE445

---

SERIA FREZÓW CZOŁOWYCH OGÓLNEGO PRZEZNACZENIA  
Z POZYTYWNYMI PŁYTKAMI 20° DO NIEZAWODNEJ  
I EFEKTYWNEJ OBRÓBKII

---



*M*plus...

# LSE445



## FREZOWANIE CZOŁOWE 45° – OBRÓBKĄ OGÓLNA

P M K N



CH: 45°  
A.R: +19°      T: +13°  
RR: -2°      I: +15°

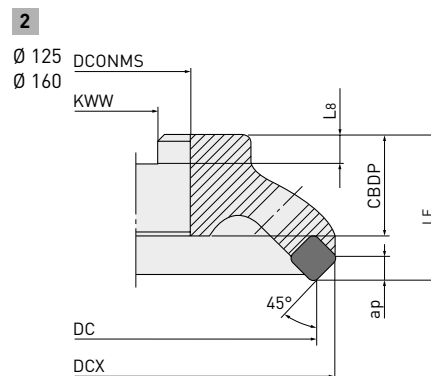
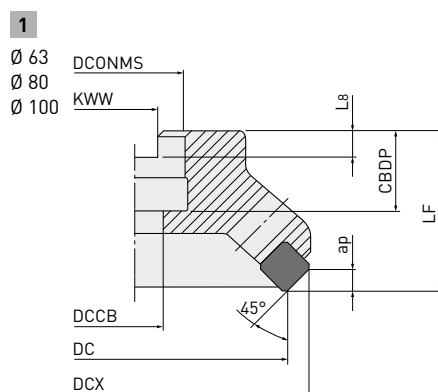

### GŁOWICA NASADZANA

Numer zamówieniowy	Dostępność		ZEFP	DC	DCX	LF	DCONMS	CBDP	DCCB	KWW	L8	WT	APMX		Typ
	R	L													
LSE445-063A05R/L-E	●	□	5	63	76.5	40	22	20	11	10.4	6.4	0.8	5.5	—	1
LSE445-080A06R/L-E	●	□	6	80	93.5	50	27	22	13.5	12.4	7.0	1.0	5.5	—	1
LSE445-100A07R/L-E	●	□	7	100	113.5	50	32	25	17.5	14.4	8.0	1.4	5.5	—	1
LSE445-125B09R/L-E	□	□	9	125	138.5	50	40	32	—	16.4	9.0	2.0	5.5	—	2
LSE445-160B11R/L-E	□	□	11	160	173.5	50	40	32	—	16.4	9.0	3.0	5.5	—	2

1/1



## CZĘŚCI ZAPASOWE

Oznaczenie oprawki narzędzia	*1					
	Płytkę podporową	Śrubę płytki podporowej	Klin	Wkręt dociskowy	Typ klucza	Typ klucza
LSE445 -063A05R/L-E				LS10T		
LSE445 -080A04R/L-E						
LSE445-100A07R/L-E	STBE445NF	CS300890T	CWSE445TR	LS15T	TKY25T	TKY08F
LSE445-125B09R/L-E						
LSE445 -160B11R/L-E						

\*1 Moment dokręcenia (N • m) : LS10T= 8.5. LS15T= 8.5. CS300890T= 1.0

# LSE445 – PŁYTKI

P	Stal	●	●		●	●	●	●	●	●	Warunki obróbki: ●: Obróbka stabilna ●: Obróbka ogólna ✖: Obróbka niestabilna
M	Stal nierdzewna	●	●		●	●	●	●	●	●	Zaszlifowanie: E: Z promieniem F: Ostre S: Fazka + zaszlifowanie T: Fazka
K	Żeliwo				✖	✖	●	✖	✖	●	Z: Wzmocnione
N	Metal nieżelazny									●	

Numer zamówieniowy	Klasa dokładności płytki	Zaszlifowanie	F7010	F7030	MC5020	VP15TF	NX2525	NX4545	UT120T	HT10	IC	S	BS	RE	Kształt
SEEN1203AFFN1	E	F								●	12.7	3.18	1.4	1.0	
SEEN1203AFEN1	E	E				●					12.7	3.18	1.4	1.0	
SEEN1203AFTN1	E	T	●				●		●		12.7	3.18	1.4	1.0	
SEEN1203AFTN3	E	T	●					●	★		12.7	3.18	1.4	—	
SEEN1203AFSN1	E	S		●	●						12.7	3.18	1.4	1.0	
SEEN1203AFSN3	E	S		●							12.7	3.18	1.4	—	
SEEN1203AFZN1	E	Z					●				12.7	3.18	1.4	1.0	

## Płytki z łamaczem wióra

SEER1203AFEN-JS	E	E	●	●	●	●					12.7	3.18	1.4	1.0	
SEER1204AFEN-JS	E	E	●								12.7	3.18	1.4	1.0	

## Płytki do obróbki gładkościowej

WEC42AFTR5C	C	T					●				—	3.18	5	1.0	
-------------	---	---	--	--	--	--	---	--	--	--	---	------	---	-----	--

1/1



# LSE445

## ZALECANE PARAMETRY SKRAWANIA

Materiał	Dureza	Calidad	Vc	fz
P	Stal konstrukcyjna	F7030	300 (200 – 360)	0.2 (0.1 – 0.3)
		NX4545		
		UTi20T		
	Stal węglowa Stal stopowa	UP20M	240 (170 – 300)	0.2 (0.1 – 0.3)
		F7030	250 (170 – 300)	
		NX4545	200 (140 – 240)	
UTi20T				
M	Stal nierdzewna	UP20M	200 (140 – 240)	0.2 (0.1 – 0.3)
		UTi20T		
		UP20M		
K	Żeliwo szare	MC5020	200 (130 – 240)	0.2 (0.1 – 0.3)
		F5010		
		F5020		
		HTi10		
		UTi20T		
N	Stopy aluminium	MD220	1000 (200 – 1500)	0.15 (0.05 – 0.25)
		HTi10	1000 (700 – 1200)	0.12 (0.05 – 0.2)

1/1

1. Obroty (min<sup>-1</sup>) = (1000 x prędkość skrawania) ÷ (3.14 x ØD1).

2. Posuw stołu (mm / min) = posuw na ostrze x liczba płytek x obroty freza.











#### GERMANY

MMC HARTMETALL GMBH  
Comeniusstr. 2 . 40670 Meerbusch  
Phone +49 2159 91890 . Fax +49 2159 918966  
Email admin@mmchg.de

#### U.K. Office

MMC HARDMETAL U.K. LTD.  
Part First Floor, 1 Centurion Court  
Centurion Way, Tamworth, B77 5PN  
Phone +44 1827 312312  
Email sales@mitsubishicarbide.co.uk

#### U.K. Deliveries/Returns

Unit 4 B5K Business Park, Quartz Close  
Tamworth, B77 4GR

#### SPAIN

MITSUBISHI MATERIALS ESPAÑA, S.A.  
Calle Emperador 2 . 46136 Museros/Valencia  
Phone +34 96 1441711  
Email comercial@mmevalencia.es

#### FRANCE

MMC METAL FRANCE S.A.R.L.  
6, Rue Jacques Monod . 91400 Orsay  
Phone +33 1 69 35 53 53 . Fax +33 1 69 35 53 50  
Email mmfsales@mmc-metal-france.fr

#### POLAND

MMC HARDMETAL POLAND SP. Z O.O.  
Al. Armii Krajowej 61 . 50-541 Wrocław  
Phone +48 71335 1620 . Fax +48 71335 1621  
Email sales@mitsubishicarbide.com.pl

#### ITALY

MMC ITALIA S.R.L.  
Viale Certosa 144 . 20156 Milano  
Phone +39 0293 77031 . Fax +39 0293 589093  
Email info@mmc-italia.it

#### TURKEY

MMC HARTMETALL GMBH ALMANYA - İZMİR MERKEZ ŞUBESİ  
Adalet Mahallesi Anadolu Caddesi No: 41-1 . 15001 35530 Bayraklı / İzmir  
Phone +90 232 5015000 . Fax +90 232 5015007  
Email info@mmchg.com.tr

[europe.mmc-carbide.com](http://europe.mmc-carbide.com)

DYSTRYBUTOR:

┌

┐

└

┘

MP103P 

MMC Hartmetall GmbH – A Sales Company of MITSUBISHI MATERIALS | 2024.01